

Trademarks

LAUNCH is a registered trademark of LAUNCH TECH CO., LTD. in China and other countries. All other marks are trademarks or registered trademarks of their respective holders.

Copyright Information

Copyright © 2024 by LAUNCH TECH CO., LTD. (also called LAUNCH for short). All rights reserved. No part of this publication may be reproduced, stored in a retrieval system, or transmitted in any form or by any means, electronic, mechanical, photocopying and recording or otherwise, without the prior written permission.

Statement: LAUNCH owns the complete intellectual property rights for the software used by this product. For any reverse engineering or cracking actions against the software, LAUNCH will block the use of this product and reserve the right to pursue their legal liabilities.

Disclaimer of Warranties and Limitation of Liabilities

All information, illustrations, and specifications in this manual are based on the latest information available at the time of publication.

The right is reserved to make changes at any time without notice. We shall not be liable for any direct, special, incidental, indirect damages or any economic consequential damages (including the loss of profits) due to the use of the document.

Using This Manual

This manual contains device usage instructions.

Some illustrations shown in this manual may contain modules and optional equipment that are not included in your system.

The following conventions are used.

Bold Text

Bold text is used to highlight selectable items such as buttons and menu options.

Example:

Tap **OK**.

Notes and Important Messages

Notes

A NOTE provides helpful information such as additional explanations, tips, and comments.

Example:

 Note: Remember to remove the VCI connector from the vehicle's DLC after use.

Warning

Warning indicates a hazardous situation which, if not avoided, could result in minor or moderate injury to the operator or to bystanders.

Example:

 Warning: Retrieving and using DTCs for troubleshooting vehicle operation is only one part of an overall diagnostic strategy. Never replace a part based only on the DTC definition. Each DTC has a set of testing procedures, instructions and flow charts that must be followed to confirm the location of the problem. This information can be found in the vehicle's service manual.

Danger

Danger indicates an imminently or potentially hazardous situation which, if not avoided, could result in death or serious injury to the operator or to bystanders.

Example:

 Danger: If you must drive the vehicle in order to perform a troubleshooting procedure, always have a second person help you. Trying to drive and operate the diagnostic tool at the same time is dangerous, and could cause a serious traffic accident.

Illustrations

Illustrations used in this manual are samples, the actual testing screen may vary for each vehicle being tested. Observe the menu titles and on-screen instructions to make correct option selection.

Important Safety Precautions

To avoid personal injury, property damage, or accidental damage to the product, read all of the information in this section before using the tool.

DANGER

- When an engine is operating, keep the service area well-ventilated or attach

LAUNCH

a building exhaust removal system to the engine exhaust system. Engines produce various poisonous compounds (hydrocarbon, carbon monoxide, nitrogen oxides, etc.) that cause slower reaction time and result in death or serious personal injury.

- Please use the included battery and power adaptor. Risk of explosion if the battery is replaced with an incorrect type.
- DO NOT attempt to operate the tool while driving the vehicle. Have second person operate the tool. Any distraction may cause an accident.

WARNING

- Always perform automotive testing in a safe environment.
- Do not connect or disconnect any test equipment while the ignition is on or the engine is running.
- Before starting the engine, put the gear lever in the Neutral position (for manual transmission) or in the Park (for automatic transmission) position to avoid injury.
- NEVER smoke or allow a spark or flame in vicinity of battery or engine. Do not operate the tool in explosive atmospheres, such as in the presence of flammable liquids, gases, or heavy dust.
- Keep a fire extinguisher suitable for gasoline/chemical/electrical fires nearby.
- Wear an ANSI-approved eye shield when testing or repairing vehicles.
- Put blocks in front of the drive wheels and never leave the vehicle unattended while testing.
- Use extreme caution when working around the ignition coil, distributor cap, ignition wires and spark plugs. These components create hazardous voltage when the engine is running.
- To avoid damaging the tool or generating false data, please make sure the vehicle battery is fully charged and the connection to the vehicle DLC (Data Link Connector) is clear and secure.
- Automotive batteries contain sulfuric acid that is harmful to skin. In operation, direct contact with the automotive batteries should be avoided. Keep the ignition sources away from the battery at all times.
- Keep the tool dry, clean, free from oil, water or grease. Use a mild detergent on a clean cloth to clear the outside of the equipment when necessary.
- Keep clothing, hair, hands, tools, test equipment, etc. away from all moving or

LAUNCH

hot engine parts.

- Store the tool and accessories in a locked area out of the reach of children.
- Do not use the tool while standing in water.
- Do not expose the tool or power adapter to rain or wet conditions. Water entering the tool or power adaptor increases the risk of electric shock.
- This tool is a sealed unit. There are no end-user serviceable parts inside. All internal repairs must be done by an authorized repair facility or qualified technician. If there is any inquiry, please contact the dealer.
- Keep the tool far away from magnetic devices because its radiations can damage the screen and erase the data stored on the tool.
- Do not attempt to replace the internal rechargeable lithium battery. Contact the dealer for factory replacement.
- Do not disconnect battery or any wiring cables in the vehicle when the ignition switch is on, as this could avoid damage to the sensors or the ECU.
- Do not place any magnetic objects near the ECU. Disconnect the power supply to the ECU before performing any welding operations on the vehicle.
- Use extreme caution when performing any operations near the ECU or sensors. Ground yourself when you disassemble PROM, otherwise ECU and sensors can be damaged by static electricity.
- When reconnecting the ECU harness connector, be sure it is attached firmly, otherwise electronic elements, such as ICs inside the ECU, can be damaged.

TABLE OF CONTENTS

1 Introduction	1
1.1 Product Profile.....	1
1.2 Package List (Only for HD III Edition)	1
1.2 Package List (Only for SmartLink C V2.0 Edition)	2
1.3 Components & Controls.....	3
1.3.1 Display tablet	3
1.3.2 VCI module (HD III).....	5
1.3.2 VCI module (SmartLink C V2.0).....	7
1.4 Technical Parameters.....	9
2 Initial Use	11
2.1 Charging & Turning On.....	11
2.2 Basic Gestures	11
2.3 Screen Layout.....	12
2.4 Adjust Brightness	12
2.5 Change System Language.....	12
2.6 Set Standby Time.....	13
2.7 Network Setup.....	13
3 Getting Started.....	14
3.1 Register & Update	14
3.2 Job Menu	16
4 Connections.....	18
4.1 Preparation	18
4.2 Communication Setup	19
5 Diagnose.....	20
5.1 Automatic Diagnosis.....	20
5.2 Local Diagnosis.....	21
5.2.1 Version Information	23
5.2.2 Read Fault Code	23
5.2.3 Clear Fault Code.....	26
5.2.4 Read Data Stream.....	27
5.2.5 Actuation Test.....	33
5.2.6 Special Function.....	33

5.3 X431 Remote Diagnostics (Only for HD III Edition)	33
5.3.1 Add Friends	34
5.3.2 Start Instant Messaging	36
5.3.3 Launch Remote Diagnosis (Scanner-To-scanner)	37
5.3.4 Launch Remote Diagnosis (Scanner-To-PC).....	40
5.3 Remote Diagnosis (Only for SmartLink C V2.0 Edition).....	42
5.3.1 SmartLink Super Remote Diagnostics.....	42
5.3.2 X431 Remote Diagnostics.....	44
6 Special (Reset) Function.....	54
6.1 DPF regeneration	54
6.2 Parameter setting	54
6.3 Cylinder cut-off, compression test	54
6.4 Injector coding.....	55
6.5 Urea drive (DEF)	55
6.6 Flash data conversion.....	55
6.7 Data optimization.....	55
6.8 Nox sensor.....	55
7 Software Update.....	56
7.1 Update Diagnostic Software & APP.....	56
7.2 Update Frequently Used software	57
7.3 Renew Subscription.....	57
8 More	59
8.1 Common Apps	59
8.1.1 Personal Center	59
8.1.2 Diagnostic History	66
8.1.3 Diagnostic Feedback.....	66
8.1.4 Toolbox.....	66
8.2 Built-in System Apps.....	66
8.2.1 Tablet Setting	66
8.2.2 Files	67
8.2.3 E-Mail.....	67
8.2.4 Camera	67
8.2.5 Gallery	67
8.2.6 Recording Master	67

LAUNCH

8.2.7 Video Player.....	67
8.2.8 Browser.....	67
8.2.9 Calculator.....	67
9 J2534 Reprogramming (Only for SmartLink C V2.0 Edition).....	68
10 FAQ.....	69

1 Introduction

1.1 Product Profile

It inherits from LAUNCH's advanced diagnosing technology and is characterized by covering a wide range of vehicles, featuring powerful functions, and providing precise test result.

Through simple wireless/wired communication between VCI (Vehicle Communication Interface) device and the display tablet, it can achieve full car and full system trouble diagnosis, which include Reading DTCs, Clearing DTCs, Reading Data Stream, Actuation Test and Special Functions.

Moreover, it also has the following other features: remote diagnosis, ADAS, repair data, vehicle coverage, software update, mall, diagnostic record, diagnostic feedback and toolbox.

1.2 Package List (Only for HD III Edition)

Common accessories are same, but for different destinations, the accessories (such as diagnostic software, testing connectors) may vary. Please consult from the seller or check the package list supplied with this tool together.

No.	Item	Descriptions	Qt.
1	Display tablet	The central processor and monitor for analyzing vehicle data and showing test results.	1
2	VCI module	A device for accessing vehicle live data.	1
3	Password envelope	A piece of paper bearing Product S/N and Activation Code, which is required for your registration.	1
4	Diagnostic cable	To connect the VCI module to vehicle's OBD II diagnostic socket.	1

LAUNCH

5	Power adaptors	To charge the tablet through connection to AC outlet.	3
6	Type A to B-shaped terminal data cable	To connect the VCI module and diagnostic tool to perform vehicle diagnosis.	1
7	Type A to Type C data cable	To connect the tablet to PC for data exchange.	1
8	Non-16pin adaptor cable kit for commercial vehicles	Check the package box for detailed non-16pin adaptor cables.	(Optional)

1.2 Package List (Only for SmartLink C V2.0 Edition)

Common accessories are same, but for different destinations, the accessories (such as diagnostic software, testing connectors) may vary. Please consult from the seller or check the package list supplied with this tool together.

No.	Item	Descriptions	Qt.
1	Display tablet	The central processor and monitor for analyzing vehicle data and showing test results.	1
2	VCI module	A device for accessing vehicle live data.	1
3	Password envelope	A piece of paper bearing Product S/N and Activation Code, which is required for your registration.	1
4	Diagnostic cable	To connect the VCI module to vehicle's OBD II diagnostic socket. It can be separated into two parts: DB15F to HD15F data cable and	1

LAUNCH

		HD15M to OBD II adaptor.	
5	Power adaptors	To charge the tablet through connection to AC outlet.	3
6	B-shaped terminal to Micro USB cable	To connect the VCI module and diagnostic tool to perform vehicle diagnosis.	1
7	Type A to Micro USB cable	To connect the tablet to PC for data exchange.	1
8	Crossover cable	Connects the VCI module for firmware upgrade.	1
9	Non-16pin adaptor cable kit for commercial vehicles	Check the package box for detailed non-16pin adaptor cables.	(Optional)

1.3 Components & Controls

There are two main components to the diagnostic system: display tablet and VCI device.

1.3.1 Display tablet

The tablet acts as the central processing system, which is used to receive and analyze the live vehicle data from the VCI device and then output the test result.

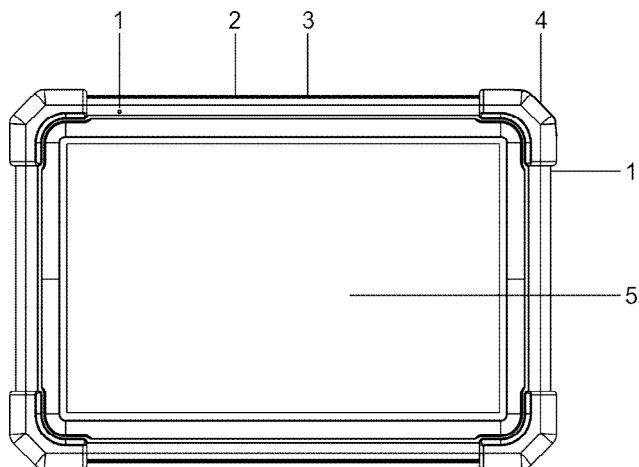

1. Microphone

2. Type-A USB Port

- Connect to the VCI connector to perform vehicle diagnosis via the data cable.
- Connect to compatible add-on modules (such as Videoscope) or USB storage devices.

3. Type-C USB Port

- Connect to AC outlet for charging.
- Connect to PC for data exchange.

4. POWER Key

Press it to turn the tablet on/off.



Note: Press and hold it for 8 seconds to perform forced shutdown.

5. LCD Screen

Indicate the test result.

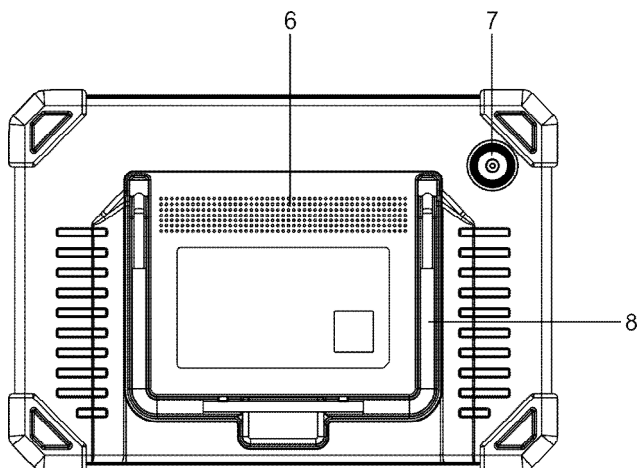

6. Speakers

7. Rear Camera

8. Adjustable stand

Flip it out to any angle and work comfortable at your desk, or hang it on steering wheel.

1.3.2 VCI module (HD III)

The HD III module works as a vehicle communication interface device. It is used to read the vehicle data and then send it to the tablet via wireless/wired communication. The LED indicators enable you to easily identify the working status of the module.

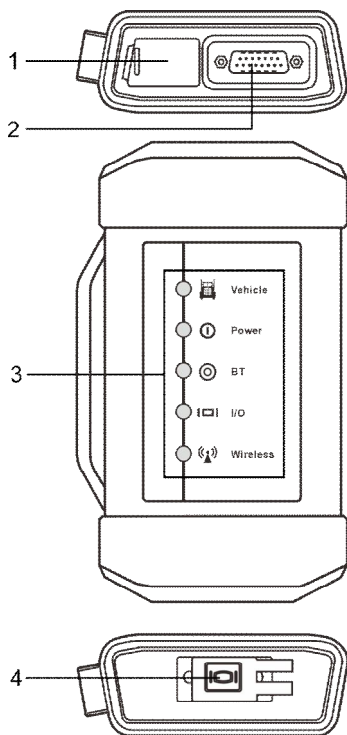

1. DC-IN power jack

Connect the power adaptor.

2. Diagnostic socket

Connect the diagnostic cable.

3. LEDs

It is defined as follows:

- Vehicle: While communicating with the vehicle, the indicator lights up and flashes. Otherwise, it will not illuminate.
- Power: It illuminates solid red when the module is powered on.
- BT: Blue indicates the module is working in Bluetooth mode.

LAUNCH

- I/O: It lights up when the module is connected to the diagnostic tool via USB cable (Currently disabled and only reserved for subsequent function extension).
- Wireless: It lights up when the module works as a Wi-Fi hotspot or wireless adaptor.

4. USB port

Currently disabled and only reserved for subsequent function extension.

1.3.2 VCI module (SmartLink C V2.0)

The SmartLink C V2.0 device features powerful functions and it can be applied in the following situations:

- 1). When as a VCI (Vehicle Communication Interface), it needs to work in conjunction with the **Diagnose** module of the tablet, which is used to obtain vehicle data, and then send it to the tablet for analysis wirelessly or via data cable.
- 2). When as a SmartLink C (Customer) dongle, it does not communicate with the tablet, but it needs to work together with the **SmartLink** module of the tablet. The tablet is mainly used to issue remote diagnostic requests, and the SmartLink C dongle is networked to receive and execute commands from the remote SmartLink B (Business).



Note: For detailed operations, please refer to Chapter 5.3.1.

- 3). When as a local J2534 PassThru device, it can be used in conjunction with the PC installed with OEM diagnostic software.



Note: For detailed operations, please refer to Chapter 10.

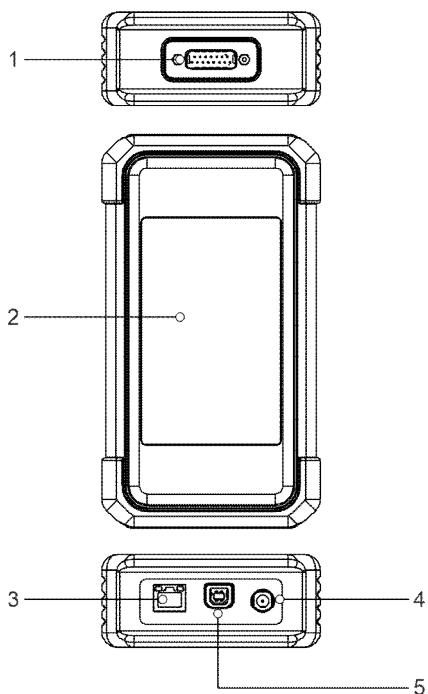

1. **DB-15 diagnostic connector**

Connect it to the vehicle's DLC (Data Link Connector) port via the diagnostic cable.

2. **Touch screen**

3. **LAN/WAN port**

Connect it to the modem via the crossover cable. It only applies to the SmartLink Super Remote Diagnostics.

4. **DC-IN power jack**

It can obtain power via connecting the diagnostic cable to the vehicle's DLC port or connecting to an external DC power supply.

⚠ Warning: It is prohibited to connect this power jack to an external DC power

supply when the SmartLink C V2.0 device is properly connected to the vehicle's DLC port.

No responsibility can be assumed for any damage or loss caused as a result of not strictly following the warning.

5. Data I/O port

- Connect it to the tablet to perform vehicle diagnosis.
- Connect it to the PC to perform J2534 reprogramming when as a J2534 PassThru device.

1.4 Technical Parameters

1. Display tablet

Operating system: Android

Memory: 4GB

Storage: 64GB

Screen: 10.1 inch capacitive touch screen with a resolution of 1280 x 800 pixels

Camera: Rear-facing 8.0MP camera

Connectivity: Wi-Fi (802.11a/b/g/n/ac)/Bluetooth/USB

Working temperature: 0°C ~ 50°C

Storage temperature: -20°C ~ 70°C

2. VCI module (HD III)

Working voltage: DC 9 ~36V

Power consumption: ≤ 3W

Communication: Wireless/Wired communication

Working temperature: 0°C~ 50°C

2. VCI module (SmartLink C V2.0)

Working voltage: DC 9~36V

Power consumption: ≤ 6W

Communication: Wireless/Wired connection

Size: 204mm x 110mm x 45mm

LAUNCH

Working temperature: -10°C ~ 50°C

2 Initial Use

2.1 Charging & Turning On

1. Plug one end of the included charging port of the tablet, and the other end to the power adaptor.
2. Connect the other end to the AC outlet to start charging. After the tablet is fully charged, unplug the power adaptor from the tablet.

 **Caution:** Please use the included power adaptor to charge your tool. No responsibility can be assumed for any damage or loss caused as a result of using power adaptors other than the one supplied.

 **Note:** If it is the first time you have used this tool or the tool remains idle for a long period of time, the tool could fail to turn on. Please charge the tool for a minimum of 5 minutes and attempt to turn on again.

Press [POWER] to turn the tool on. Press [POWER] for 3 seconds, an option menu will pop up on the screen. Tap **Power off** to turn the tool off.

2.2 Basic Gestures



Single-tap: To select an item or launch a program.



Double-tap: To zoom in so that the text on a webpage appears in a column that fits your device's screen.



Long press: Tap and hold on the current interface or area until a contextual menu pops up on the screen, and then release it.



Slide: To jump to different pages.



Drag: Tap the application icon and drop it to other location.

LAUNCH



Spread apart/pinch together: To zoom in manually, place two fingers on the screen and then spread them apart. To zoom out, place two fingers apart on the screen and then pinch them together.

2.3 Screen Layout

There are five on-screen buttons available on the bottom of the screen.



Home: Navigates to the Android's home screen.



Recent App: Views the recently launched applications and running applications.



VCI Connection: Shows whether the VCI device is properly connected or not.



Screenshot: Captures the current screen.



Back: Returns to the previous screen.

2.4 Adjust Brightness



Note: Reducing the brightness of the screen is helpful to conserve the battery power.

1. On the home screen, tap **Settings -> Display -> Brightness level**.
2. Drag the slider to adjust it.

2.5 Change System Language

The tool supports multiple system languages. To change the language of the tool, please do the following:

1. On the home screen, tap **Settings -> System -> Language & input -> Languages**.
2. Tap **Add a language**, and then choose the desired language from the list.
3. Tap and hold the desired language and drag it to the top of the screen and then release it, the system will change into the target language.

2.6 Set Standby Time

If no activities are made within the defined standby period, the screen will be locked automatically and the system enters sleep mode to save power.

1. On the home screen, tap **Settings -> Display -> Advanced -> Sleep**.
2. Choose the desired sleep time.

2.7 Network Setup

The tablet has built-in Wi-Fi that can be used to get online. Once you're online, you can register your tool, surf the Internet, get apps, send email, launch the remote diagnosis, and check for software updates etc.

1. On the home screen, tap **Settings -> Network & Internet -> WLAN**.
2. Slide the Wi-Fi switch to ON, the tablet starts searching for available wireless networks.
3. Select a wireless network,
 - If the chosen network is open, the tablet will connect automatically.
 - If the selected network is encrypted, a network password will need to be entered.
4. When **Connected** appears, it indicates the Wi-Fi connection is complete.

 Note: When Wi-Fi is not required, this should be disabled to conserve battery power.

3 Getting Started

For new users, you will need to experience a user registration process before getting started.

3.1 Register & Update

Follow the steps below to proceed registration and update:

Tap the application icon on the home screen to launch it, and then tap **Login** to enter the login interface of diagnosis software.

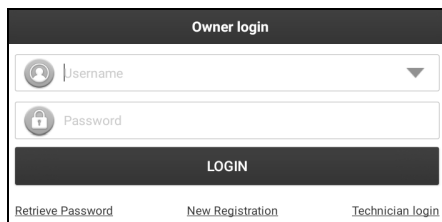

(If you are a new user, follow **A** to proceed.)

(If you have registered to be a member, go to **B** to login the system directly.)

(If you have bound a sub-account to this tool, go to **C** to login the system.)

(In case you forgot password, refer to **D** to reset a new password.)

A. If you are a new user, tap **New Registration** to enter the sign-up page.

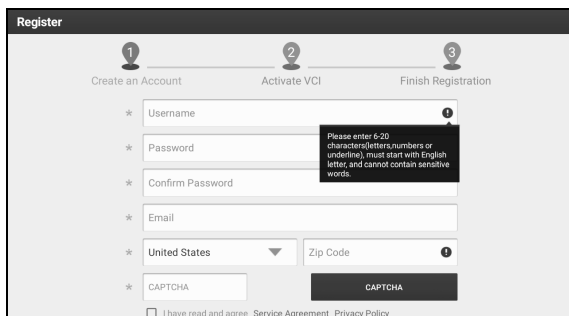

Fill in the information in each field (Items with * must be filled). After inputting,

LAUNCH

tap **Register**, the following screen will appear:

The screenshot shows the 'Register' screen with three steps: 1. Create an Account, 2. Activate VCI, and 3. Finish Registration. The 'Activate VCI' step is active. It features two input fields: 'Serial Number' and 'Activation Code'. Below the fields is an 'ACTIVATE' button. A note states: 'Your VCI's 12 digit serial number and 8 digit Activation Code can be found in the envelope pictured below.' Below the note are two images of envelopes, one showing the front and one showing the back with a seal.

Input the 12-digit Product Serial Number and 8-digit Activation Code (can be obtained from the password envelope), and then tap **Activate**.

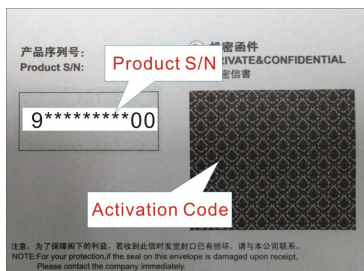

Tap **OK** to navigate to the update center to update all available software.

The screenshot shows the 'Register' screen with three steps: 1. Create an Account, 2. Activate VCI, and 3. Finish Registration. The 'Finish Registration' step is active. It features a message: 'Congratulations! You have successfully completed your registration. click OK to download the model software.' Below the message is an 'OK' button.

LAUNCH

After the registration is successfully complete, the wireless communication between the tablet and the VCI device is automatically established and user has no need to configure it again.

B. If you have registered to be a member, input your name and password, and then tap **LOGIN** to enter the main menu screen directly.

 **Note:** The tablet has an auto-save function. Once the username and password are correctly entered, the system will automatically store it. Next time you login the system, you will not be asked to input the account manually.

C. If you have created a sub-account or bound an existing account to the tool, tap **Technician login** to login. For more details on sub-accounts, refer to Chapter 8.1.1.

D. If you forgot the password, tap **Retrieve password** and then follow on-screen instructions to set a new password.

3.2 Job Menu

It mainly includes the following items:

Name	Description
Automatic Diagnosis	Automatically decode the vehicle VIN and quickly access to the vehicle system.
Local Diagnose	Diagnose a vehicle manually.
Remote Diagnose	It helps repair shops or mechanics to diagnose a remote vehicle, and launch instant messages, allowing for improved efficiency and faster repairs.
Special Functions	It offers coding, reset, relearn and more service functions, to help vehicles get back to functional status after repair or replacement.
ADAS	This function enables users to perform ADAS (Advanced Driver Assistance System) calibration operations. The ADAS calibration software is disabled by default. Before using this function, users must

LAUNCH

	activate the ADAS function using the ADAS Activation Card.
Vehicle Coverage	View all the vehicle models that the tool covers.
Info Center	Include abundant repair information (Operation skills, DTC help, technology handbook and Repair case).
Upgrade Center	Update vehicle diagnostic software and APK.
Mall	An online diagnostic software store. This module enables you to subscribe some extra software or service functions that are not integrated in the tool online.
More	Include some mini apps associated with diagnostics, add-on modules and some frequently used built-in apps.

4 Connections

4.1 Preparation

1. Make sure that the ignition is turned off and the vehicle battery voltage range is 18-30V.
2. Find DLC location. For commercial vehicles, the DLC is always located in driver's cab. If the DLC cannot be found, refer to the vehicle's service manual for the location.
3. The method used to connect the VCI module to a vehicle's DLC depends on the vehicle's configuration as follows:
 - A. OBD II Vehicle Connection: Plug one end of the diagnostic cable into the vehicle's DLC, and the other end into the diagnostic socket of the VCI module, and then tighten the captive screws.

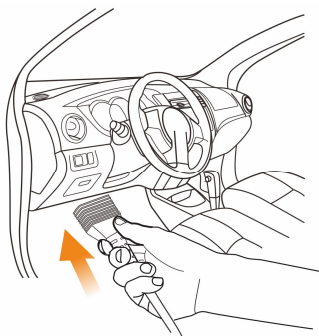

- B. Non-OBD II Vehicle Connection: For vehicles with non-OBD II diagnostic socket, a non-16pin adaptor cable is required.

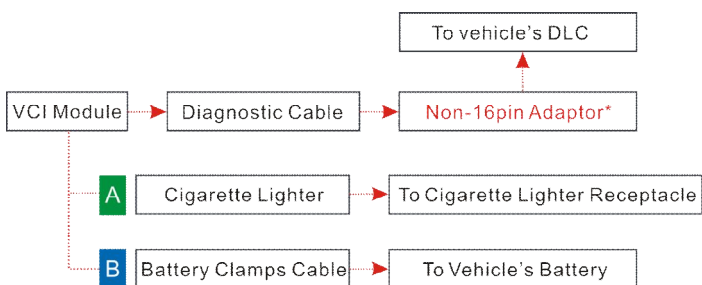

4. Turn the ignition on. Now the tool is ready for diagnosis.

4.2 Communication Setup

There are two kinds of ways available for the tablet to communicate with the VCI device: wireless and wired (USB).

After the user registration is successfully finished, the wireless communication between the tablet and the VCI device is automatically established and user has no need to configure it again.

The USB connection is a simple & quick way to establish communication between the tablet and the VCI. After properly connecting the data cable from the tablet to the VCI, the VCI navigation button at the bottom of the screen will be enabled indicating the USB connection is successful.

 **Note:** The USB connection provides the most stable and fastest communication. When all communication methods are applied at the same time, the tablet will use the wired communication as the default priority.

5 Diagnose

5.1 Automatic Diagnosis

Through simple wireless communication between the tablet and VCI, you can quickly scan all available systems of the currently identified vehicle. Once the automatic detection is successfully performed, the system will directly output the scan result.

Notes:

- Before using this function, please make sure the VCI is properly connected to the vehicle's DLC port. For detailed connection, see Chapter 4.2.
- A stable network connection is required for this function.

Follow the steps below to proceed.

1. Tap **Automatic Diagnosis**, choose the desired vehicle region on the popup, the following screen will appear.



2. After the vehicle manufacturer region is selected, the system will automatically decode the vehicle information.

If the system fails to decode the vehicle, the following popup will appear on the screen. Enter the 17-digit VIN manually to start scanning.

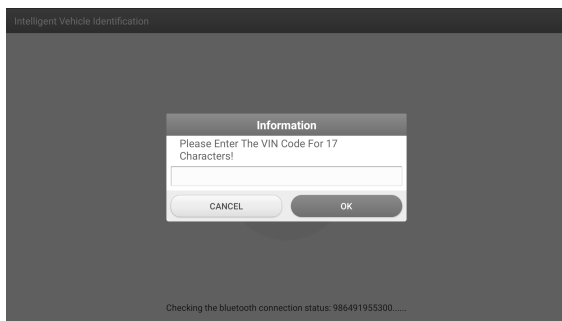

3. After the vehicle VIN is successfully decoded, the tablet will automatically scan all available systems.
4. Tap the desired system to scan until the test result appears on the screen.

5.2 Local Diagnosis

Tap **Local Diagnosis** to enter the vehicle selection page.

Tap a corresponding diagnostic software logo, and then follow the on-screen instruction to access the diagnostic software.

Take Demo (V15.01) as an example to demonstrate how to diagnose a vehicle.

- 1). Select diagnostic software version: Tap the **TRUCK -> DEMO** to go to Step 2.

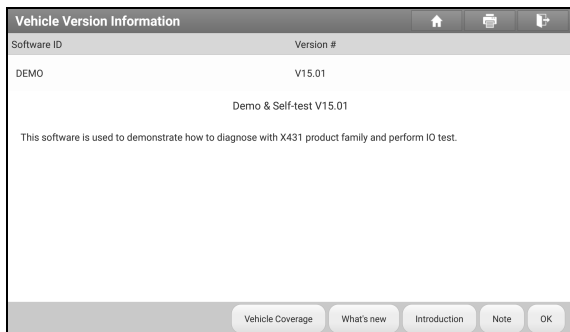

On-screen Buttons:

Vehicle Coverage: Tap to view the vehicle models that the current diagnostic

LAUNCH

software covers.

What's new: Tap to view the optimized items and enhancements.

Introduction: Tap to check the software function list.

Note: Tap to read some precautions on using the current diagnostic software.

OK: Tap it to go to next step.

The diagnostics toolbar contains a number of buttons that enable various procedures. It is displayed at the top of the vehicle diagnostic screen throughout the whole diagnostic session. Refer to the table below for a brief description of the functions of the diagnostics toolbar buttons:

 **Home:** Return to the home screen.

 **Print:** Tap to print the selected screenshots out via external printer. The printer needs to be configured separately. For details on printer setting, refer to Chapter 9.1.1.

 **Exit:** Exit the diagnostic application.

2). **Select test item:** Select the desired test item to proceed. Here we take **Freightliner** for example to demonstrate how to diagnose a vehicle.

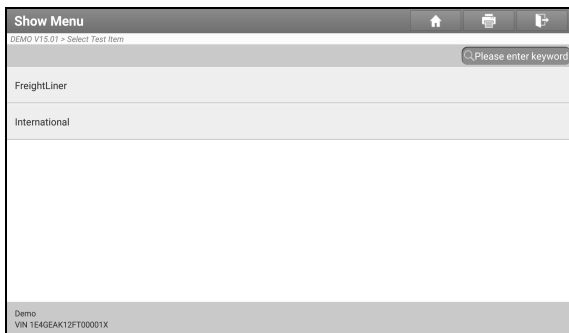

3). **Select test system:** Select the desired test system to continue.

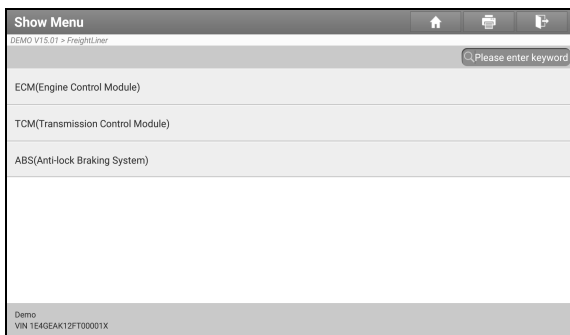

4). Select test function: Select the desired test function.

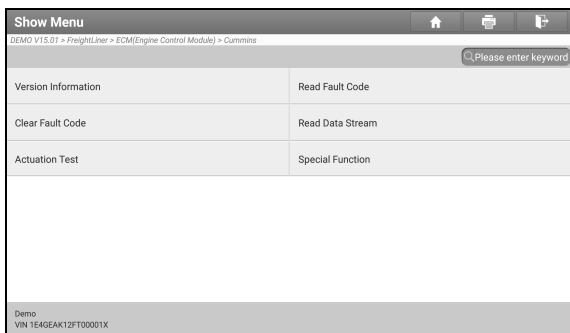

 Note: Different vehicle has different diagnostic menus.

5.2.1 Version Information

This function is used to read the version information of system mode, vehicle VIN, software and ECU.

5.2.2 Read Fault Code

This function displays the detailed information of DTC records retrieved from the vehicle's control system.

 **Caution:** Retrieving and using DTCs for troubleshooting vehicle operation is only one part of an overall diagnostic strategy. Never replace a part based only on the DTC definition. Each DTC has a set of testing procedures, instructions and flow charts that

LAUNCH

must be followed to confirm cause of the problem. Refer to vehicle's service manual for detailed testing instructions.

On the diagnostic function selection screen, tap **Read Fault Code**, the screen will display the diagnostic result.

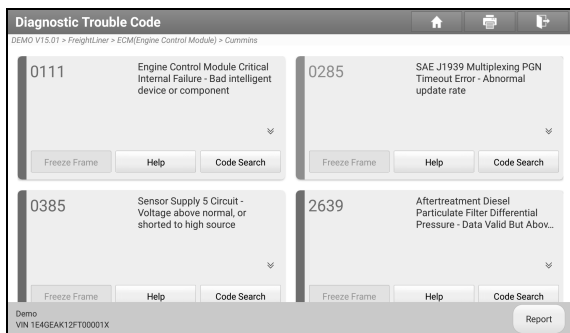

On-screen Buttons:

Freeze Frame: Tap to check the snapshot of critical parameter values at the time the DTC is set. When an emission-related fault occurs, certain vehicle conditions are recorded by the on-board computer. This information is referred to as freeze frame data.

Help: Tap to view the help information.

Code Search: Tap to search for more information about the current DTC online.

Report: Tap to save the current data in text format.

Report Information

Report Type
Pre-Repair

Vehicle Information
Demo: Demo
Year: 35565 km
License #: 1E4GEAK12FT00001X

Report Info
Report Info: Demo_1E4GEAK12FT00001X_DTC_20221012145940
Notes:

OK

 Note: Diagnostic report is classified into three categories: Pre-Repair report, Post-Repair report and Diagnostic Scan. No matter which type you saved the report as, the report type will be appended as a tag on the upper right corner of the diagnostic report for easier identification.

Tap ▼ to select the report type from the option list and input the required information, and then tap **OK**.

 Note: To facilitate the comparison of the pre-repair and post-repair reports and get accurate test result, please make sure you saved the right type of the diagnostic report.

To save the report as a common diagnostic report, select **Diagnostic Scan**.

More Information

Shop Name: test
Telephone: 15367898765
Address line1
Address line2
City: sz
State
Zip Code

Email: f.h@id.com
Technician Name
Repair Order No
Customer Name
Country

OK

 Note: For workshop information, tap the input box to enter it. Alternatively you can also set it in **More -> Common -> Personal Center -> Settings -> Shop Information**. Once you configured the information, it will be automatically generated every time you

saved the diagnostic report. All vehicle and workshop information will be appended as tags on the diagnostic report.

To ignore the workshop information, tap **Skip** to go to the report details screen.

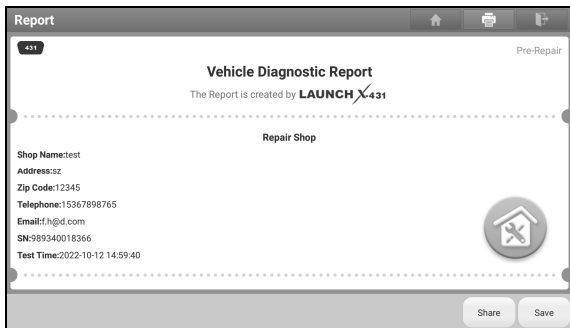

On the report details screen, tap **Save** to save it. All reports are saved in **More -> Common -> Personal center -> My Report -> Health Reports**. For details on report operations, please refer to Chapter 9.1.1.

5.2.3 Clear Fault Code

This function enables you to erase the codes from the vehicle after reading the retrieved codes from the vehicle and certain repairs have been carried out. Before performing this function, make sure the vehicle's ignition key is in the ON position with the engine off.

Clearing DTCs does not fix the problem(s) that caused the code(s) to be set. If proper repairs to correct the problem that caused the code(s) to be set are not made, the code(s) will appear again and the check engine light will illuminate as soon as the problem that cause the DTC to set manifests itself.

On the diagnostic function selection screen, tap **Clear Fault Code**, a confirmation dialog box will appear.

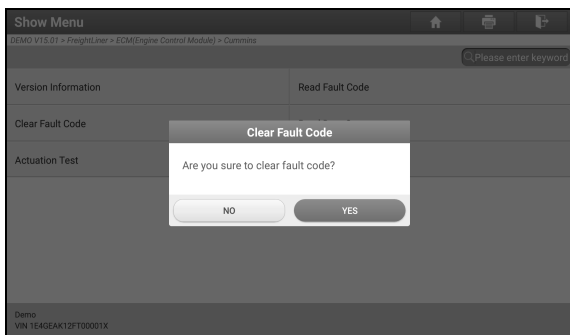



Tap **YES**, the system will automatically delete the currently existing trouble code.

 **Note:** After clearing, you should retrieve trouble codes once more or turn ignition on and retrieve codes again. If there are still some trouble codes in the system, please troubleshoot the code using a factory diagnosis guide, then clear the code and recheck.

5.2.4 Read Data Stream

This option lets you view and capture (record) real-time Live Data. This data including current operating status for parameters and/or sensor information can provide insight on overall vehicle performance. It can also be used to guide vehicle repair.

 **Caution:** If you must drive the vehicle in order to perform a troubleshooting procedure, ALWAYS have a second person help you. Trying to drive and operate the diagnostic tool at the same time is dangerous, and could cause a serious traffic accident.

 **Note:** The real time (Live Data) vehicle operating information (values/status) that the on-board computer supplies to the tool for each sensor, actuator, switch, etc. is called Parameter Identification Data (PID).

On the diagnostic function selection screen, tap **Read Data Stream**, the following screen will appear.

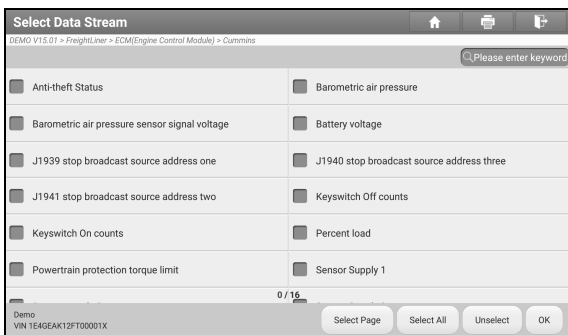

On-screen Buttons:

Select Page: Tap to select all items of the current page.

Select All: Tap to select all items. To select certain data stream item, just check the box before the item name.

Unselect: Tap to deselect all data stream items.

OK: Tap to confirm and jump to the next step.

After selecting the desired items, tap **OK** to enter the data stream reading page.

Name	Value	Standard Range	English	Metric
Anti-theft Status	-			
Barometric air pressure	84	100 - 500	kPa	
Barometric air pressure sensor signal voltage	7.06	5 - 25	V	
Battery voltage	7.06	5 - 25	V	
J1939 stop broadcast source address one	5376		count	
J1940 stop broadcast source address three	5376		count	
	(1 / 2)			

Notes:

1. If the value of the data stream item is out of the range of the standard (reference) value, the whole line will display in red. If it complies with the reference value, it displays in blue (normal mode).

LAUNCH

2. The indicator 1/X shown on the bottom of the screen stands for the current page/total page number. Swipe the screen from the right/left to advance/return to the next/previous page.

There are 3 types of display modes available for data viewing, allowing you to view various types of parameters in the most suitable way.

- ✓ Value – This is the default mode which displays the parameters in texts and shows in list format.
- ✓ Graph – Displays the parameters in waveform graphs.
- ✓ Combine – This option is mostly used in graph merge status for data comparison. In this case, different items are marked in different colors.

On-screen Buttons:

 **Graph(Single):** Tap to view the parameter in waveform graph.

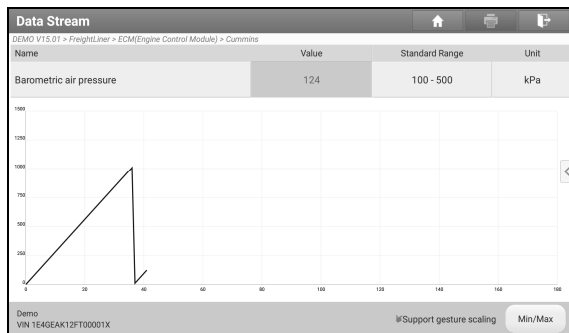

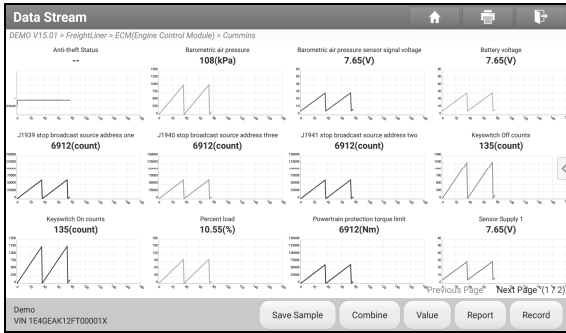

- **Min/Max:** Tap to define the maximum / minimum value. Once the value goes beyond the specified value, the system will alarm.

Graph: Tap to view the parameters in waveform graphs.

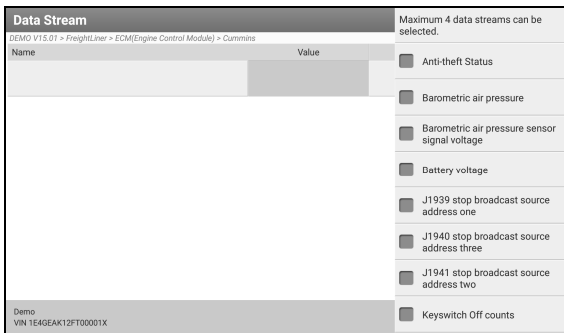

- Combine:** This option is mostly used in graph merge status for data comparison. In this case, different items are marked in different colors (maximum 4 items can be displayed on the same screen simultaneously). If the graph is more than one page, swipe the screen from the left to jump to the next page.



- Value:** Switches the current graph display mode to the Value display mode.
- Customize:** Tap , a pull-down list of the data stream items appears on the screen. Select / deselect the desired items, and then screen will display / remove the waveforms corresponding to these items immediately.

Compare Sample: Tap to select the sample DS file.

All the values you customized and saved in process of data stream sampling will

be imported into the **Standard Range** (See below) column for your comparison.

 **Note:** Before executing this function, you have to sample the values of data stream items and save it as a sample Data Stream file.

Data Stream				
DEMO V15.01 > Freightliner > ECM(Engine Control Module) > Cummins				
Name	Value	Standard Range(Sample)	English	Metric
Anti-theft Status	--			
Barometric air pressure	728	20 - 1016	kPa	
Barometric air pressure sensor signal voltage	22.84	5.49 - 29.9	V	
Battery voltage	22.84	5.49 - 29.9	V	
J1939 stop broadcast source address one	46592	1280 - 65024	count	
J1940 stop broadcast source address three	46592 (1 / 2)	1280 - 65024	count	

Demo VIN 1E4GEAK12FT00001X

Compare Sample Save Sample Graph Report Record Help

Report: Tap to save the current data in text format. All reports are saved in **More -> Common -> Personal center -> My Report -> Health Reports**. For details on report operations, please refer to Chapter 9.1.1.

Record: Tap to start recording diagnostic data. Recorded live data can serve as valuable information to help you in troubleshooting of vehicle problems.

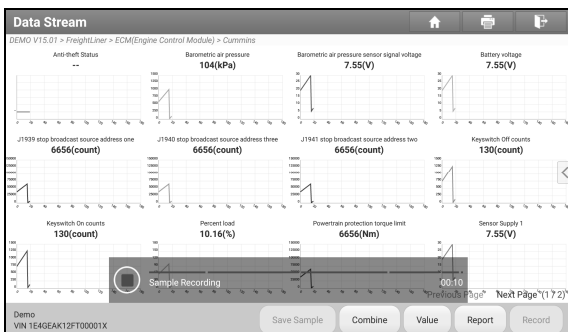

Tap  to end recording and save it. The saved file follows the naming rule: It begins with vehicle type, and then the product S/N and ends with record starting time (To differentiate between files, please configure the accurate system time).

All diagnostic records can be replayed from **More -> Common -> Personal**

center -> My Report -> Recorded Data.

Save Sample: This item enables you to customize the standard range of live data stream items and save it as data stream sample file. Each time you run the data stream items, you can call out the corresponding sample data to overwrite the current standard range.

Tap it to start recording the sample data (📄) Note: Only data stream items with measurement units will be recorded), the following screen will appear:

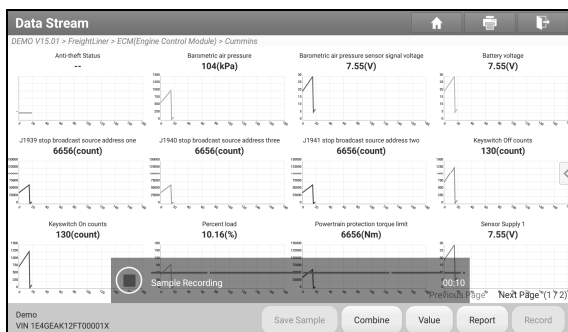

Once the recording process is complete, tap (⏹) to stop it and navigate to the data revision screen.

Name	Min Value	Max Value	Unit
Barometric air pressure	20.0	1016.0	Kpa
Barometric air pressure sensor signal voltage	5.49	29.9	V
Battery voltage	5.49	29.9	V
J1939 stop broadcast source address one	1280.0	65024.0	count
J1940 stop broadcast source address three	1280.0	65024.0	count
J1941 stop broadcast source address two	1280.0	65024.0	count
Keyswitch Off counts	0.0	130.0	count

At the bottom right, there is a 'Save' button.

Tap the Min./Max. value to change it. After modifying all desired items, tap **Save** to save it as a sample DS file. All DS files are stored in **More -> Common -> Personal center -> Sample**.

5.2.5 Actuation Test

This option is used to access vehicle-specific subsystem and component tests. Available test vary by vehicle manufacturer, year, and model.

During the actuation test, the display tablet outputs commands to the ECU in order to drive the actuators, and then determines the integrity of the system or parts by reading the ECU data, or by monitoring the operation of the actuators, such as switching an injector between two operating states.

On the diagnostic function selection screen, tap **Actuation Test**, the system will display as follows:

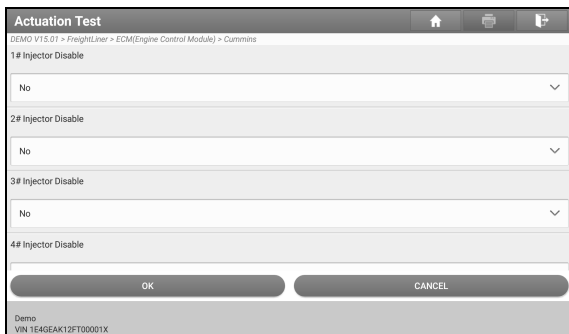

Simply follow the on-screen instructions and make appropriate selections to complete the test.

Each time when an operation is successfully executed, "Completed" displays.

5.2.6 Special Function

It offers coding, reset, relearn and more service functions, to help vehicles get back to functional status after repair or replacement.

5.3 X431 Remote Diagnostics (Only for HD III Edition)

This module helps repair shops or mechanics to diagnose a remote vehicle, and launch instant messages, allowing for improved efficiency and faster repairs.

Tap **Remote Diagnosis** on the Job menu, the screen appears blank by default.

LAUNCH

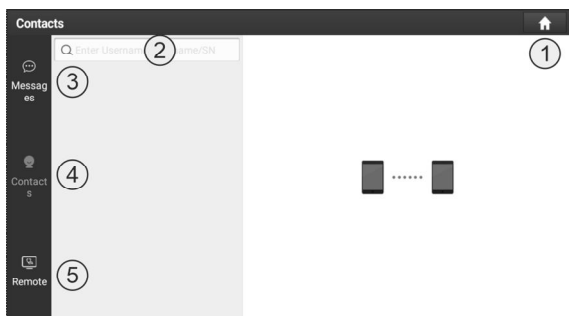

1	Home Button	Navigate to the Job menu screen.
2	Search Bar	Directly input the username of the tool for searching, and then tap the desired one to add it into Contacts list.
3	Messages Tab	A red dot will appear indicating a received message.
4	Contacts Tab	Enter the friend list.
5	Remote Switch	Your technician can control your tool remotely once the switch is ON.

5.3.1 Add Friends

Tap **Contacts**. By default it appears blank.

In the search bar, input the partner's username and tap **Search** to start searching.

The partner must be the users who have registered specific diagnostic tools.

They may be the following:

- Workshop
- Technician
- golo users

Once the result matches the keyword, the following screen will appear:

LAUNCH

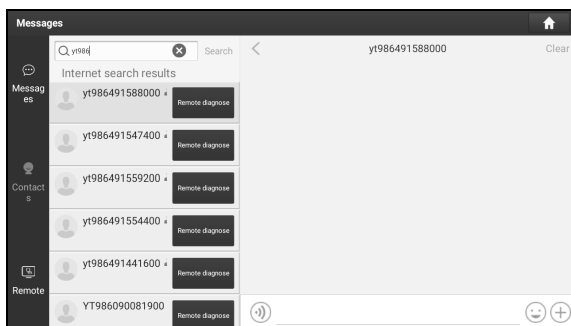

Here you can tap **Remote Diagnose** to launch remote diagnostics directly or choose to add the partner into the Contacts list.

Tap the desired name from the list, the following screen will appear:

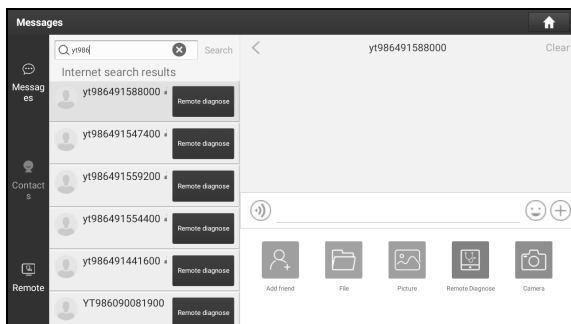

Tap **Add friend** to send your request.

Once the partner receives the request, a beep will sound. Tap **Messages**:

- Once the partner agreed your request, he/she will automatically be listed in the Contacts tab.
- If a technician sent you a friend request, tap **Agree** and his/her name will appear in the Contacts list. Or tap **Ignore** to ignore this request.

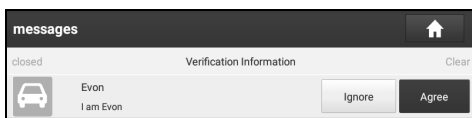

5.3.2 Start Instant Messaging

The I/M (Instant Messaging) function is open to all users who had the diagnostic tool equipped with this module.

After adding your friends, tap the desired one's photo to enter the following screen:

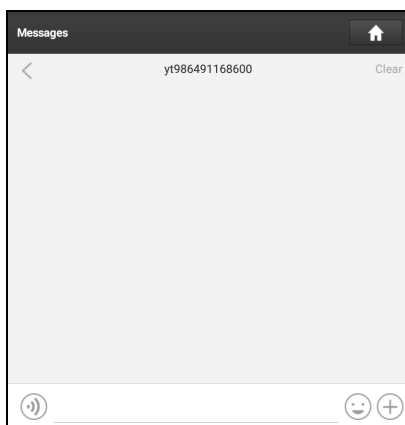

Tap the input field and use the on-screen keyboard to send the text message.

Tap 🎙️ to send the voice message.

Tap 😊 to send the emoji.

Tap ➕ to call out more function options.

LAUNCH

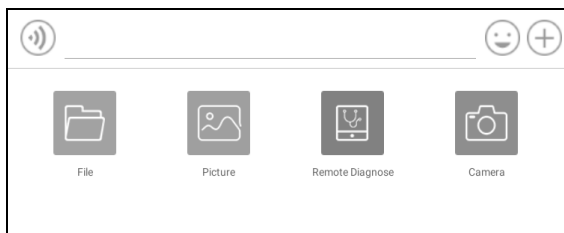

File: Choose diagnostic reports or local files to send.

Picture: Choose screenshots or pictures to send.

Remote Diagnose: To start a remote diagnostic session. For details, refer to Chapter 5.3.4.

Camera: Open camera to take pictures.



5.3.3 Launch Remote Diagnosis (Scanner-To-scanner)

The tool is allowed to initiate remote diagnosis with other diagnostic tools, which are equipped with this module.

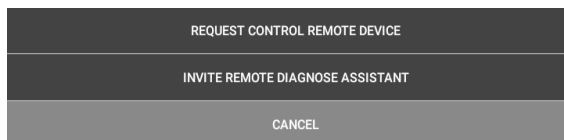

On the function option selection screen, tap **Remote Diagnostic**, the following pull-down menu will appear:



These options are defined as follows:

Actions	Results
Request control remote device	<p>Request to control the partner's device remotely to help him diagnose the vehicle.</p> <p> Notes:</p> <ul style="list-style-type: none">• In process of remote diagnosis, tap the  button to send a voice message.• Once vehicle diagnosis is complete, a report will be created. Input your comments on this report, and then

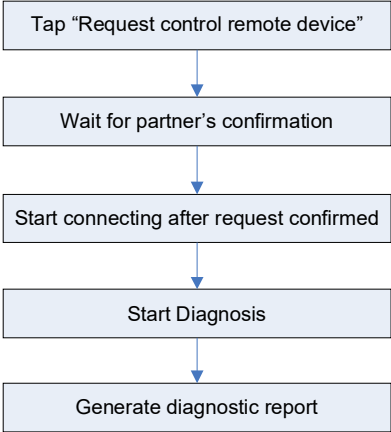
LAUNCH

	<p>tap Send Report to send it to the partner.</p>  <pre>graph TD; A[Tap "Request control remote device"] --> B[Wait for partner's confirmation]; B --> C[Start connecting after request confirmed]; C --> D[Start Diagnosis]; D --> E[Generate diagnostic report];</pre>
Invite remote diagnostic assistant	<p>Use this option to invite a technician to perform a remote control on your tool.</p> <p> Notes:</p> <ul style="list-style-type: none">• In process of remote diagnosis, tap the  button to send a voice message.• Once you received the report from the partner, tap View Report to view details. All diagnostic reports are saved under More -> Common Apps -> Personal Center -> My Report -> Remote Reports.

LAUNCH

	<pre>graph TD; A[Tap "Invite remote diagnostic assistant"] --> B[Choose the desired diagnostic software]; B --> C[Wait for partner's confirmation]; C --> D[Start connecting after request confirmed]; D --> E[Start Diagnosis]; E --> F[Generate diagnostic report];</pre>
Cancel	To cancel this operation.

5.3.4 Launch Remote Diagnosis (Scanner-To-PC)

User also can ask for remote control from a PC client technician.

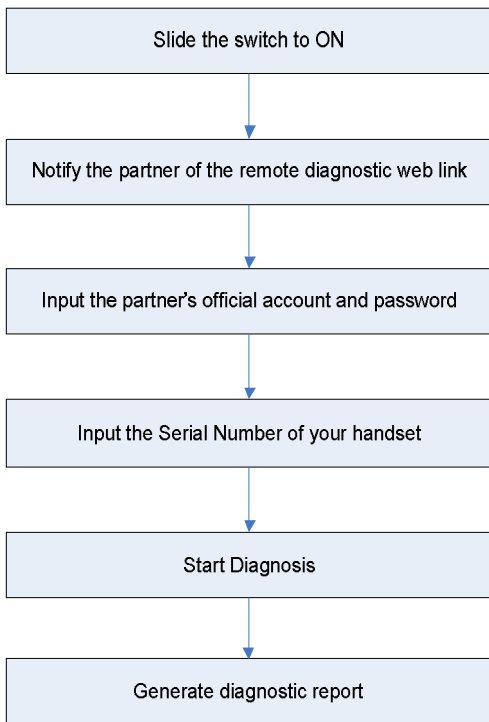

Tap **Remote**, the following screen will appear:

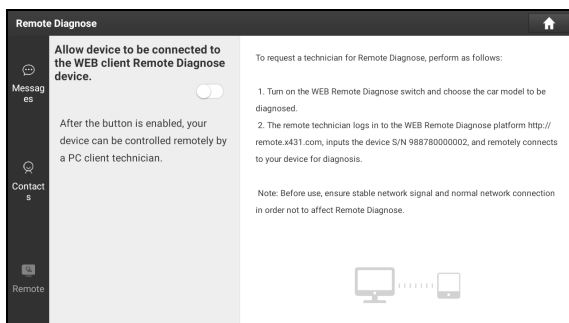

1. Slide the switch to ON so that the partner can find and connect to this device while using the PC.
2. Notify the partner of the PC client website <http://remote.x431.com>. When the partner accesses the link, the PC displays as below:

 Note: Before processing remote diagnosis, please make sure the tool is properly connected to the vehicle.

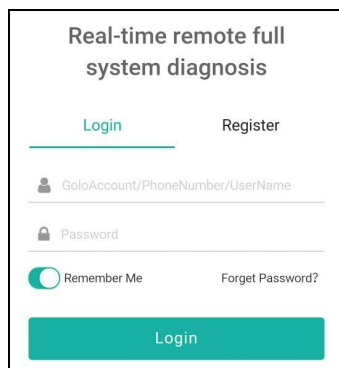

3. Tell the partner to input his own official technician account and password, and then tap **Login** to navigate to the following figure.

Remote diagnosis

Serial Number
Locate the car to be diagnosed according to
golo/AIT serial number

License Plate Number
Locate the car to be diagnosed according to the
car owner's license plate number

Phone Number
Locate the car to be diagnosed according to the
car owner's phone number

97229000223

Start remote diagnosis

Tips: Before starting remote diagnosis, confirm the car
owner's car information and condition

4. Tell the partner to enter the Serial Number provided by you, and then tap **Start remote diagnosis** to control your device remotely.

In process of remote diagnosis, please note the following things:

- 1) You are not suggested to execute any actions.
- 2) The partner is not allowed to save any diagnostic reports or records on your tablet.

Once the session is complete, a remote diagnostic report will be automatically generated.

5.3 Remote Diagnosis (Only for SmartLink C V2.0 Edition)

5.3.1 SmartLink Super Remote Diagnostics

SmartLink is a newly developed powerful service system dedicated to remote vehicle diagnosis and service. In the SmartLink ecology system, if a technician (SmartLink C) does not have time to puzzle through a touch vehicle problem, he can seek a trusted second opinion or additional expertise on various vehicle issues from remote master technicians or repair shops (SmartLink B). SmartLink B enables the shop owner to greatly increase customer's retention and boost shop revenue by providing the professional technical assistance service.

It mainly consists of the following parts:

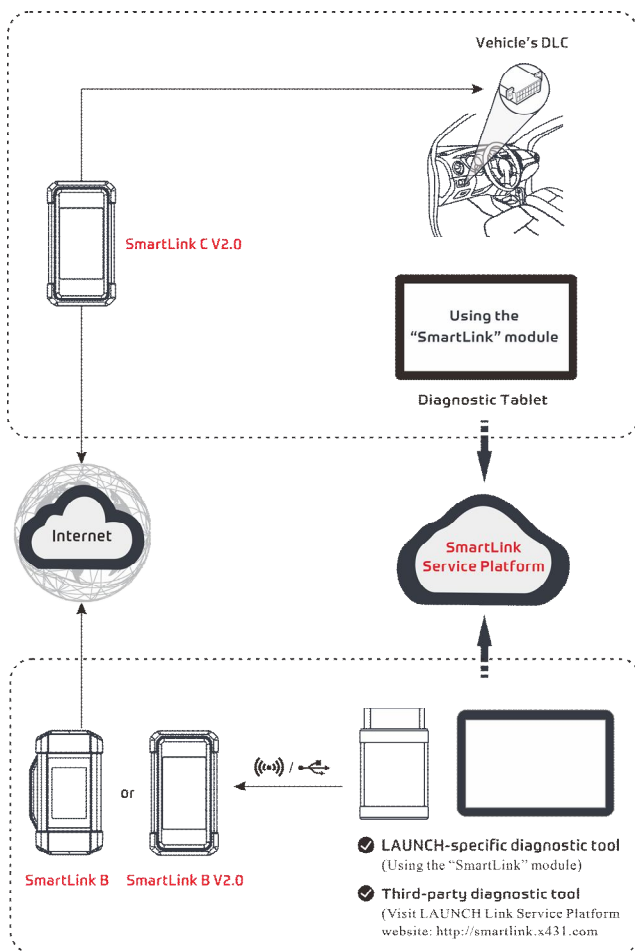

- **SmartLink Service Platform** – It can be accessed from the **SmartLink** module of the diagnostic tablet. There are two modules available on the link service platform: **Common user** (for SmartLink C) and **Service provider** (for SmartLink B).
- **SmartLink C (Customer)** - **SmartLink Service Subscriber**. In the

LAUNCH

SmartLink system, the SmartLink C needs to perform the following operations.

- 1). Launch Service Link Platform: Binds SmartLink C dongles and submits remote repair orders.
- 2). SmartLink C Dongle: Connects to the vehicle's DLC port for collecting the vehicle data and sends it to the remote SmartLink B.

It supports remote diagnostic services for vehicles that meet CAN / CAN FD / J2534 vehicle diagnostic standards.

- **SmartLink B (Business) - SmartLink Service Provider.** In the SmartLink system, the SmartLink B needs to perform the following operations.
 - 1). Launch Service Link Platform: Binds SmartLink B dongles and accepts orders from SmartLink C.
 - If the SmartLink B dongle works with the LAUNCH-specific diagnostic tool equipped with SmartLink module, tap **SmartLink** to add the SmartLink B device and accepts orders on the diagnostic tool.
 - If the SmartLink B dongle works with the third-party diagnostic tool, open the browser and visit SmartLink Service Platform website <http://smartlink.x431.com> (web client) to add the SmartLink B device and accepts orders in the browser.
 - 2). SmartLink B Dongle: After accepting the orders, it can work with the compatible diagnostic tool to perform diagnosis of the vehicle connected to the SmartLink C dongle.

For more detailed operations, refer to the User Manual integrated in the SmartLink Platform.

5.3.2 X431 Remote Diagnostics

This module helps repair shops or mechanics to diagnose a remote vehicle, and launch instant messages, allowing for improved efficiency and faster repairs.

Tap **Remote Diagnosis -> X431 Remote Diagnosis** on the Job menu, the screen appears blank by default.

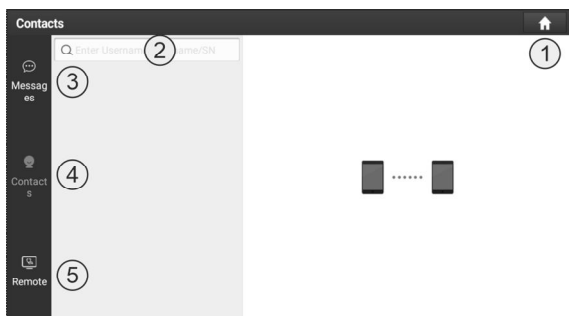

1	Home Button	Navigate to the Job menu screen.
2	Search Bar	Directly input the username of the tool for searching, and then tap the desired one to add it into Contacts list.
3	Messages Tab	A red dot will appear indicating a received message.
4	Contacts Tab	Enter the friend list.
5	Remote Switch	Your technician can control your tool remotely once the switch is ON.

1. Add Friends

Tap **Contacts**. By default it appears blank.

In the search bar, input the partner's username and tap **Search** to start searching.

The partner must be the users who have registered specific diagnostic tools. They may be the following:

- Workshop
- Technician
- golo users

Once the result matches the keyword, the following screen will appear:

LAUNCH

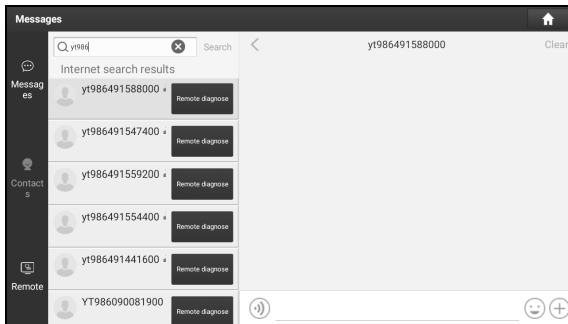

Here you can tap **Remote Diagnose** to launch remote diagnostics directly or choose to add the partner into the Contacts list.

Tap the desired name from the list, the following screen will appear:

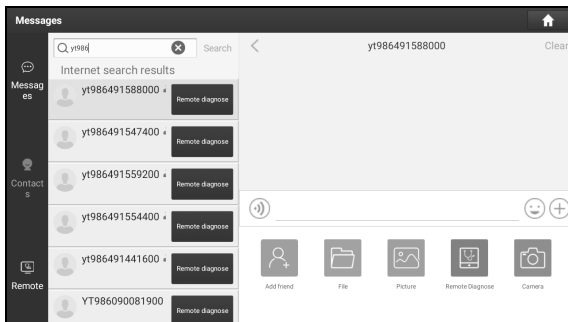

Tap **Add friend** to send your request.

Once the partner receives the request, a beep will sound. Tap **Messages**:

- Once the partner agreed your request, he/she will automatically be listed in the Contacts tab.
- If a technician sent you a friend request, tap **Agree** and his/her name will appear in the Contacts list. Or tap **Ignore** to ignore this request.

LAUNCH

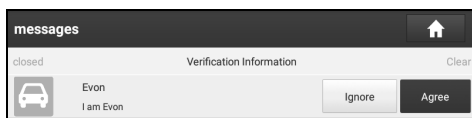

2. Start Instant Messaging

The I/M (Instant Messaging) function is open to all users who had the diagnostic tool equipped with this module.

After adding your friends, tap the desired one's photo to enter the following screen:

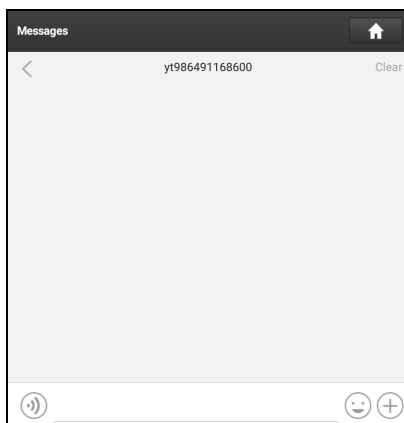

Tap the input field and use the on-screen keyboard to send the text message.

Tap  to send the voice message.

Tap  to send the emoji.

Tap  to call out more function options.

LAUNCH

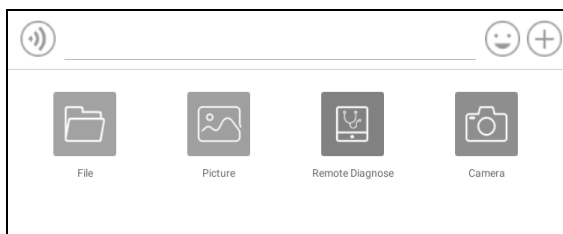

File: Choose diagnostic reports or local files to send.

Picture: Choose screenshots or pictures to send.

Remote Diagnose: To start a remote diagnostic session. For details, refer to Chapter 5.3.4.

Camera: Open camera to take pictures.



3. Launch Remote Diagnosis (Scanner-To-Scanner)

The tool is allowed to initiate remote diagnosis with other diagnostic tools, which are equipped with this module.

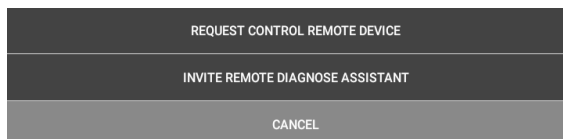

On the function option selection screen, tap **Remote Diagnostic**, the following pull-down menu will appear:



These options are defined as follows:

Actions	Results
Request control remote device	<p>Request to control the partner's device remotely to help him diagnose the vehicle.</p> <p> Notes:</p> <ul style="list-style-type: none">• In process of remote diagnosis, tap the  button to send a voice message.• Once vehicle diagnosis is complete, a report will be created. Input your comments on this report, and then

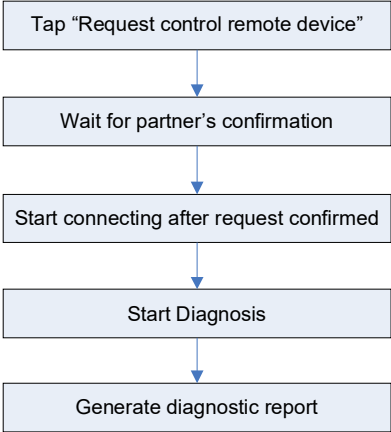
LAUNCH

	<p>tap Send Report to send it to the partner.</p>  <pre>graph TD; A[Tap "Request control remote device"] --> B[Wait for partner's confirmation]; B --> C[Start connecting after request confirmed]; C --> D[Start Diagnosis]; D --> E[Generate diagnostic report];</pre>
Invite remote diagnostic assistant	<p>Use this option to invite a technician to perform a remote control on your tool.</p> <p> Notes:</p> <ul style="list-style-type: none">• In process of remote diagnosis, tap the  button to send a voice message.• Once you received the report from the partner, tap View Report to view details. All diagnostic reports are saved under More -> Common Apps -> Personal Center -> My Report -> Remote Reports.

LAUNCH

	<pre>graph TD; A[Tap "Invite remote diagnostic assistant"] --> B[Choose the desired diagnostic software]; B --> C[Wait for partner's confirmation]; C --> D[Start connecting after request confirmed]; D --> E[Start Diagnosis]; E --> F[Generate diagnostic report];</pre>
Cancel	To cancel this operation.

4. Launch Remote Diagnosis (Scanner-To-PC)

User also can ask for remote control from a PC client technician.

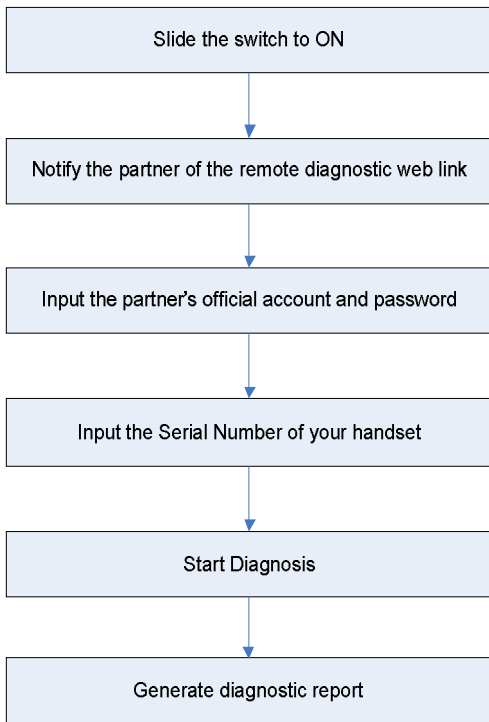

Tap **Remote**, the following screen will appear:

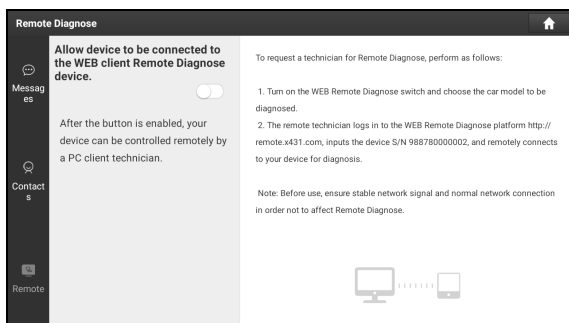

5. Slide the switch to ON so that the partner can find and connect to this device while using the PC.
6. Notify the partner of the PC client website <http://remote.x431.com>. When the partner accesses the link, the PC displays as below:

 Note: Before processing remote diagnosis, please make sure the tool is properly connected to the vehicle.

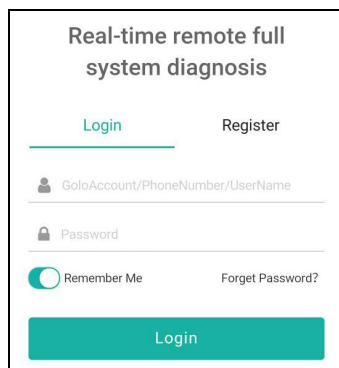

7. Tell the partner to input his own official technician account and password, and then tap **Login** to navigate to the following figure.

Remote diagnosis

Serial Number
Locate the car to be diagnosed according to
golo/AIT serial number

License Plate Number
Locate the car to be diagnosed according to the
car owner's license plate number

Phone Number
Locate the car to be diagnosed according to the
car owner's phone number

Start remote diagnosis

Tips: Before starting remote diagnosis, confirm the car
owner's car information and condition

8. Tell the partner to enter the Serial Number provided by you, and then tap **Start remote diagnosis** to control your device remotely.

In process of remote diagnosis, please note the following things:

- 1) You are not suggested to execute any actions.
- 2) The partner is not allowed to save any diagnostic reports or records on your tablet.

Once the session is complete, a remote diagnostic report will be automatically generated.

6 Special (Reset) Function

This module provides an easy dial to quickly access the most commonly performed service functions.

It offers coding, reset, relearn and more service functions, to help vehicles get back to functional status after repair or replacement. Available tests vary by vehicle manufacturer, year, and model.

Due to continuing improvements, the available service functions are subject to change at any time. To enjoy more service functions, you are suggested to check for updates on a regular basis.

6.1 DPF regeneration

This function can help remove PM (Particulate Matters) from the DPF filter by using combustion oxidation methods (such as high temperature heating combustion, fuel additive or catalyst reduce PM ignition combustion) to keep the performance of the filter stable.

It needs to be performed in the following cases:

- The exhaust back pressure sensor is replaced.
- The PM trap is removed or replaced.
- The fuel additive nozzle is removed or replaced.
- The catalytic oxidizer is removed or replaced.
- The DPF regeneration MIL is on and maintenance is performed.
- The DPF regeneration control module is replaced.

6.2 Parameter setting

This function enables you to set certain parameter, such as VIN, injector data and EIN etc.

6.3 Cylinder cut-off, compression test

This function can cut off certain cylinder when the engine is running to identify which one is working improperly. Users can judge whether certain cylinder is normal or not by separately cutting off certain cylinder and checking the working

status of the engine.

It needs to be performed in the following cases:

- When engine is running abnormally or certain cylinder does not work.

6.4 Injector coding

This function can write injector actual code or rewrite code in the ECU to the injector code of the corresponding cylinder, so as to control or correct the cylinder injection quantity accurately.

It needs to be performed in the following cases:

- After the ECU or injector is replaced.

6.5 Urea drive (DEF)

This function can drive the urea pump to perform reverse pumping, compression, injection and other operations through the diagnostic scanner.

It needs to be performed in the following cases:

- After the urea pump maintenance is performed.

6.6 Flash data conversion

This function enables you to convert the backup data into standard format data such as .hex, .s19 and .bin etc.

It needs to be performed in the following cases:

- Need the standard format data to perform other operations.

6.7 Data optimization

This function enables you to optimize the vehicle power by revising vehicle data.

6.8 Nox sensor

NOx sensor is a sensor used to detect the content of nitrogen oxides (NOx) in engine exhaust. If the NOx fault is re-initialized and the NOx catalytic converter is replaced, it is necessary to reset the catalytic converter learned value stored in the engine ECU.

7 Software Update

This module enables you to update the diagnostic software & App and frequently used software.

7.1 Update Diagnostic Software & APP

Go to **Upgrade Center** on the Job Menu and tap the **Downloaded** tab.

The **Available** tab displays a list of software that can be updated. Under it, all software is categorized into three kinds:

- **Common software:** mainly includes some common apps that are associated with the diagnostic app. The software of this kind always stays at the top of the list, which can be deselected manually (excluding the system app, such as firmware and ECU aid).
 - **Frequently used vehicle software:** refers to the diagnostic software that is frequently used, including the vehicle diagnostic software and Reset software. It is generally displayed following the **Common software** list.
 - **Other vehicle software:** refers to the diagnostic software that is rarely used or never used. It is generally displayed following the **Frequently used software** list.
- 1). If the user does not download any diagnostic software during the sign-up process, all diagnostic software is selected by default. Tap **Update** to start downloading.
 - 2). If the user downloaded all/some vehicle software during the sign-up process and had it serviced for a long period of time, only the frequently used software is selected. Tap **Update** to start downloading. Other vehicle software that is rarely used will also be listed under the **Available** tab, but it is not selected at default.

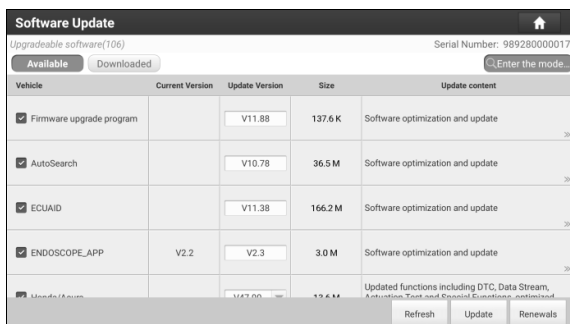

To download certain software that is not frequently used, check the box before the vehicle model. Tap **Update** to start downloading.

Once download is finished, the software packages will be installed automatically.

7.2 Update Frequently Used software

If the user only intends to update the frequently used software, go to Software Update and tap the **Downloaded** tab.

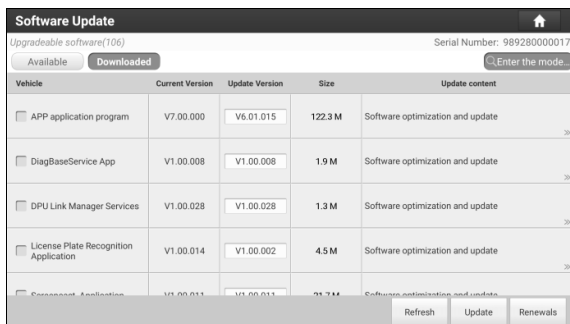

Tap **Update** to start downloading. Once download is finished, the software packages will be installed automatically.

7.3 Renew Subscription

If the software subscription is due or expires, tap **Renewals** to enter **Mall** to

LAUNCH

renew the subscription.

8 More

This module includes some mini apps associated with diagnostics, add-on modules and some frequently used built-in apps.

8.1 Common Apps

This function allows users to manage personal information, VCI and make some in-app system settings.

8.1.1 Personal Center

This function allows users to manage personal information and VCI.

1. My Report

This option is used to view, delete or share the saved reports.

Tap **My Report**, there are total 3 options available.

- 1). If the DTC result is saved on Read Trouble Code page, the files will be listed under **Health Reports** tab. All diagnostic reports are sorted by Date and Make. Tap the desired type to re-arrange and filter it.
- 2). **Remote Reports** lists all diagnostic reports generated in process of remote diagnosis.
- 3). If user records the running parameters while reading data stream, it will be saved as .x431 file and appear under **Recorded Data** tab.

2. VCI

This option allows you to manage all your activated VCIs.

If several VCIs are activated on this tool, a list of VCIs will be displayed on the screen. Once you choose the VCI that belongs to other account, you have to log out, and then input the right account to continue.

3. VCI Management

This option is used to set the communication method between the tablet and the VCI module.

To ensure the tablet can work with the VCI module via Wi-Fi communication, please follow the steps below to proceed:

LAUNCH

1. Check the box “Use Wi-Fi communication mode”, the system will search for VCI module automatically.
2. Tap the target VCI to pair. Once the pairing is successfully done, the screen displays:

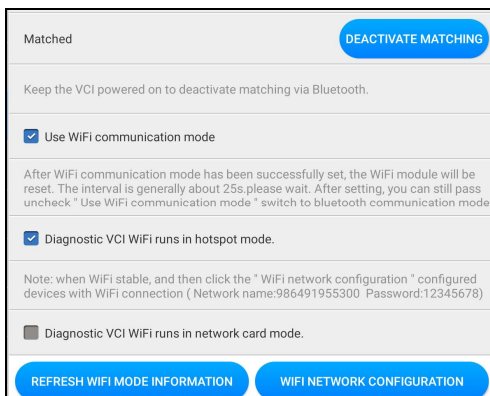

3. There are two Wi-Fi communication modes available for the VCI module.
 - Work in Wi-Fi hotspot: Once enabled, the VCI module and the tablet automatically connect and form a LAN network to make communication. In this case, the tablet cannot surf the Internet.
 - Work in network adaptor: Once enabled, input the Wi-Fi network name and access password (if the network is encrypted) until it is properly connected. In this case, the tablet can surf the Internet and communicate with the VCI module.



Note: please be sure to keep the VCI powered on while performing the operation.

4. Activate VCI

This item lets you activate a new VCI.

Input the Serial Number and Activation Code, and then tap **Activate** to activate it.

5. Firmware Fix

Use this item to upgrade and fix VCI firmware/system. During fixing, please do

LAUNCH

not cut power or switch to other interfaces.

6. Sample

This feature allows you to manage the recorded data stream sample files.

7. My Order

This item allows you to check the status of all your orders.

8. Subscription Renewal Card

This item is used to check the status of the subscription renewal card.

Input the 12-digit subscription renewal card number. Tap **Search** to get the search result.

9. Profile

Use this item to view and configure personal information.

10. Change Password

This item allows you to modify your login password.

11. Settings

It enables you to make some application settings and view software version information etc.

1) Units

It is designed to configure the measurement unit. Metric System and English System are available.

2) Shop information

This option lets you define your print information. It mainly includes Workshop, Address, Telephone, Fax and License Plate.

After inputting, tap **Save**.

Once you saved the print information, it will be entered automatically in the "Add Information" box every time you save the diagnostic report.

3) Printer set

This option is designed to establish a wireless connection between the tablet and the Wi-Fi printer (sold separately) while performing printing operations.

LAUNCH

The App is compatible with the **LAUNCH Wi-Fi Printer** (sold separately) and **System** (external printer).

For LAUNCH Wi-Fi printer, refer to the User Manual included with the Wi-Fi printer to configure the printer settings.

For other Wi-Fi printers,

Before printing, make sure the following conditions are met:

- The Wi-Fi printer is powered on and working normally.
- The print service plug-in associated with the printer is already installed on the tablet (Go to Google Play or use the Browser to download and install it).

Follow the steps below to proceed:

1. Set the default printer as **System**.
2. Go to **More -> Built-in apps -> Tablet Settings -> WLAN**, set the WLAN switch to Off.
3. On the report details page, tap .

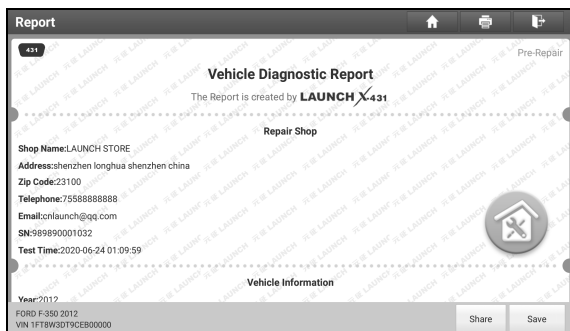

4. Touch  next to **Select a printer** on the upper left corner of the screen.

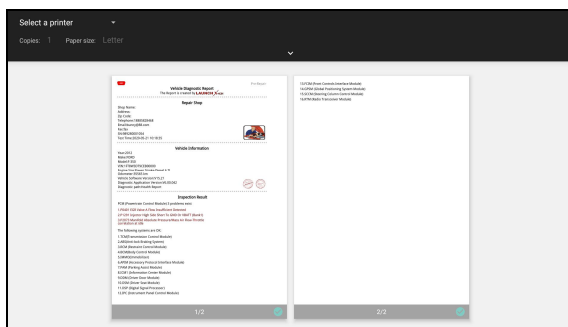

5. Select **All Printers** -> **Add printer** and enable the installed printer service, the system starts searching for all available Wi-Fi printers of the brand.

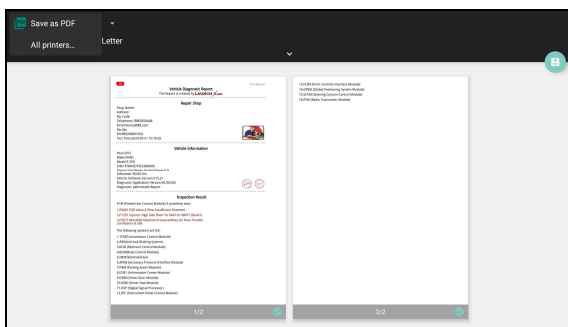

6. Select the desired Wi-Fi printer from the list. If the chosen Wi-Fi printer hotspot is open, the tablet can connect it directly. If it is encrypted, a password may be required. Refer to the Wi-Fi printer user manual to get the default password.
7. Now the printer is ready for printing.
8. Alternatively, you can also choose **Save as PDF** to save the current diagnostic report as a PDF file for later printing.

4) Clear cache

This item is used to clear the App cache.

Tap **Clear Cache**, a pop-up window will appear on the screen. Tap **OK** to clear

cache and the system will restart the App.

5) About

The software version information and disclaimer are included.

6) Diagnostic software auto update

This option is used to set whether automatic update function is ON.

7) Device account management

This option is used to manage the sub-accounts. The added sub-account allows the VCI connector to be used by different users to log in the tool, which is convenient for multiple VCIs to perform diagnostic service at the same time.

The newly added sub-account has a one-year validity period. After the expiration, the VCI bound to the sub-account cannot be used and the sub-account will no longer enjoy the rights and interests of the main account. The main account can modify the validity period of the sub-account.

There are two types of sub-accounts: one is an existing account and the other is a newly created account. The main account has the functions of adding and removing sub-accounts, the sub-account can also be unbound from the main account.

Tap **Device account management**, the following screen will appear:

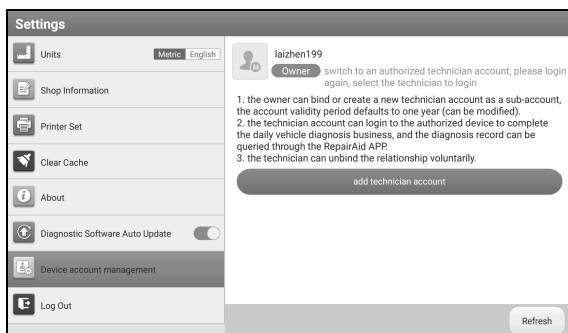

Tap **Add technician account**, the following popup will appear:

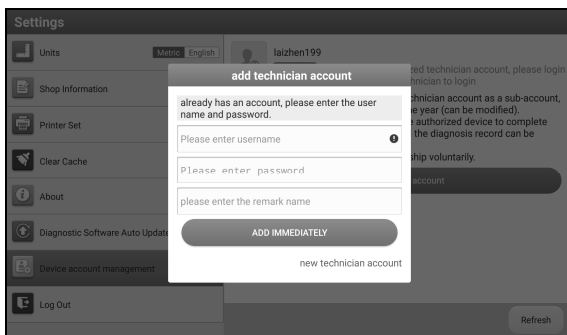

- If you already have an account, please enter the user name and password. After inputting, tap **Add Immediately** to add it as a sub-account.
- If you have not registered any account, tap Create sub user. Enter the user name and password, and then tap **Add Immediately** to add it as a sub-account.

After adding the sub-account, the following screen will appear:

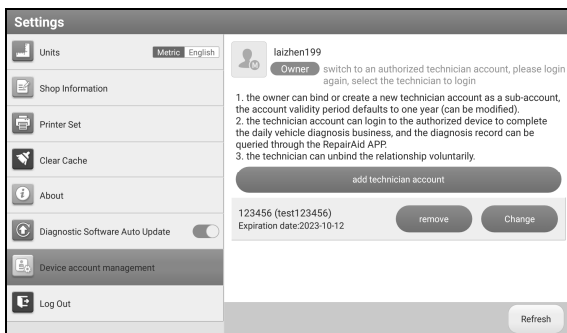

To unbind it from the main account, tap **Remove**. To revise the validity period, tap **Change**.

8) Login/Log out

To logout the current user ID, tap **Log Out**.

To login the system again, tap **Login**.

12. Diagnostic Software Clear

This item allows you to hide/clear the diagnostic software that is not frequently used.

8.1.2 Diagnostic History

When a vehicle diagnosis is performed, the tablet records the detailed diagnostic information. The History function allows access to previously tested vehicle records. Testing can be resumed from the previous operation without starting from scratch.

8.1.3 Diagnostic Feedback

This function allows you to send the feedback of your diagnostic problems to us for further analysis and troubleshooting.

There are 3 options:

- 1) Diag. Feedback: To send a tested vehicle diagnostic feedback.
- 2) History Feedback: To view all diagnostic feedback records.
- 3) Offline Feedback: To view all diagnostic feedback logs that have failed to be submitted, which will be uploaded again to the remote server automatically once the tablet gets the stable network.

8.1.4 Toolbox

This function includes the following add-on modules: Oscilloscope, Ignition Scope, Sensor Simulator, Multimeter, Battery Tester and Videoscope.

Each module consists of two parts: hardware and application. These applications cannot work properly on the tablet, which need to work with the specific compatible hardware (sold separately). For detailed operations, refer to the User Manual of each module.

8.2 Built-in System Apps

This module includes some commonly used applications of Android's system.

8.2.1 Tablet Setting

This application provides a quick dial to the Android's system settings. Alternatively, it also can be accessed by tapping the Settings on the Android home screen.

8.2.2 Files

The application is a file, download, application manager and task killer.

For more information, please refer to the associated ES file explorer documents.

8.2.3 E-Mail

It is an easy-to-use email app that saves you time and keeps your messages safe. Get your emails instantly via push notifications, read and respond online & offline, and find any email quickly.

8.2.4 Camera

This application allows you to take pictures or record videos with the device camera.

8.2.5 Gallery

This function allows you to take new pictures and manage the picture library (including screenshots).

8.2.6 Recording Master

This application is a free and convenient application that allows you to take tablet screen video capture of high quality, with or without sound.

8.2.7 Video Player

This application is a media player supporting all types of video formats.

8.2.8 Browser

This application is a free cross-platform web browser.

8.2.9 Calculator

It is a simple-to-use and responsive app. All calculations are made on-the-fly as you input new data.

9 J2534 Reprogramming (Only for SmartLink C V2.0 Edition)

Flash programming has become a common and profitable procedure in the repair and service of today's vehicles. Reprogramming is often the only solution for problems ranging from driveability and loss of power to poor fuel economy and emissions related issues. SmartLink C V2.0 makes it easy. The SmartLink C V2.0 is a communication interface designed to support J2534 specifications for ECU reprogramming.

Except that the SmartLink C V2.0 can act as a VCI device and a SmartLink dongle, it also can be used as a J2534 PassThru device, working together with the PC installed with the OEM diagnostic software to perform the J2534 reprogramming. In this case, the PC needs to install with the LAUNCH's J2534 tool, which can be downloaded from the official website at www.cnlaunch.com.

PC installed with OEM
diagnostic software

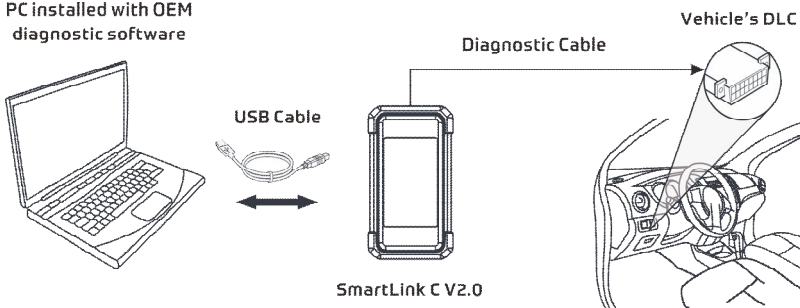

10 FAQ

1. How to save power?

- Please turn off the screen while the tool keeps idle.
- Set a shorter standby time.
- Decrease the brightness of the screen.
- If WLAN connection is not required, please turn it off.
- Disable GPS function if GPS service is not in use.

2. Communication error with vehicle ECU?

Please confirm:

1. Whether diagnostic connector is correctly connected.
2. Whether ignition switch is ON.
3. If all checks are normal, send vehicle year, make, model and VIN number to us using Feedback feature.

3. Failed to enter into vehicle ECU system?

Please confirm:

1. Whether the vehicle is equipped with this system.
2. Whether the VCI dongle is correctly connected.
3. Whether ignition switch is ON.
4. If all checks are normal, send vehicle year, make, model and VIN number to us using Feedback feature.

4. How to download the diagnostic App after resetting the tablet?



Note: Before registration, please make sure the network is properly connected.

After the tablet has been successfully reset, follow the steps below to download the App:

1. Launch the browser and the default official Launch website opens (If a blank page pops up, just type in www.x431.com in the input bar).
2. Tap **Login**, input the username and password and tap **Log In**.
3. Make sure that the serial number is correct, tap **APP application program**

LAUNCH

and tap the Download icon to start downloading.

4. After the download is complete, follow the on-screen instructions to install it.
5. After installation, use the existing username and password to login and go to update center to download the diagnostic software.

5. What to do if the language of vehicle diagnostic software does not match the system language?

English is the default system language of the tool. After the system language is set to the preference language, please go to the update center to download the vehicle diagnostic software of the corresponding language.

If the downloaded diagnostic software is still displayed in English, it indicates that the software of the current language is under development.

6. How to retrieve the login password?

Please follow below steps to proceed in case you forgot the login password:

1. Tap the application icon on the home screen to launch it.
2. Tap **Login** on the upper right corner of the screen.
3. Tap **Retrieve password**.
4. Input product S/N and follow the on-screen prompts to retrieve the password.

Warranty

THIS WARRANTY IS EXPRESSLY LIMITED TO PERSONS WHO PURCHASE LAUNCH PRODUCTS FOR PURPOSES OF RESALE OR USE IN THE ORDINARY COURSE OF THE BUYER'S BUSINESS.

LAUNCH electronic product is warranted against defects in materials and workmanship for one year from date of delivery to the user.

This warranty does not cover any part that has been abused, altered, used for a purpose other than for which it was intended, or used in a manner inconsistent with instructions regarding use. The exclusive remedy for any automotive meter found to be defective is repair or replacement, and LAUNCH shall not be liable for any consequential or incidental damages.

Final determination of defects shall be made by LAUNCH in accordance with procedures established by LAUNCH. No agent, employee, or representative of LAUNCH has any authority to bind LAUNCH to any affirmation, representation, or warranty concerning LAUNCH automotive meters, except as stated herein.

Disclaimer

The above warranty is in lieu of any other warranty, expressed or implied, including any warranty of merchantability or fitness for a particular purpose.

Purchase Order

Replaceable and optional parts can be ordered directly from your LAUNCH authorized tool supplier. Your order should include the following information:

- Order quantity
- Part number
- Part name

Customer Service

If you have any questions during the operation of the unit, please contact the Seller, or contact LAUNCH TECH Service Center.

Website: <https://en.cnlaunch.com>

Phone: +86 755 8455 7891

Email: overseas.service@cnlaunch.com

Statement:

LAUNCH reserves the rights to make any change to product designs and specifications without notice. The actual object may differ a little from the descriptions in the manual in physical appearance, color and configuration. We have tried our best to make the descriptions and illustrations in the manual as accurate as possible, and defects are inevitable, if you have any question, please contact local dealer or after-sale service center of LAUNCH, LAUNCH does not bear any responsibility arising from misunderstandings.